



LIGHT EMITTING DIODE SPECIFICATION

CUSTOMER NAME:

DESCRIPTION: E6Z3535RGBC4-D04HA-1.00H-RGB04

REVISION: V2.2

ISSUE DATE: 2023-06-21

Contains trade secret information which is the property of Ekinglux and shall not be made available to, or copied or used by anyone outside Ekinglux without its written authorization. Copyright © 2017 Ekinglux Optoelectronics Technology Co., Ltd. All rights reserved

Features:

- Power input voltage: 3.5-7.5V
- OUT R/G/B constant current value: 12mA
- Top SMD internally integrates high-quality external control single-wire serial cascade constant current IC
- The control circuit and chip are integrated in the SMD 3535 components, forming a complete external control pixel, with uniform color temperature effect and high consistency
- Built-in data shaping circuit, any pixel receives the signal after waveform shaping and then outputs it to ensure that the line waveform distortion will not accumulate
- By default, the light does not light when powered on
- Grayscale adjustment circuit (256-level grayscale adjustable)
- Data shaping: After receiving the data of this unit, the subsequent data will be automatically shaped and output
- Built-in high precision and high stability oscillator
- Single-wire data transmission, infinite cascade
- High data protocol compatibility
- Data transmission rate: 800Kbps

Application:

- Full-color module, Full color soft lights a lamp strip.
- LED decorative lighting, Indoor/outdoor LED video irregular screen.



Product description:

This is a three-channel LED driver control chip with single-wire transmission, using unipolar return-to-zero code protocol. It includes power clamp module, signal decoding module, oscillation module, data regeneration module, output current drive module and so on. The data regeneration module automatically reshapes and forwards the data output by the cascade after receiving the data of the chip, so as to ensure that the data serial transmission process is not attenuated.

Built-in output current setting module, the default output current of OUT/RGB port is 12MA

It is an intelligent externally controlled LED light source that integrates the control circuit and the light-emitting circuit. Its layman is the same as the conventional SMD3535LED lamp bead, and each component is a pixel.

The single-wire communication method is adopted, and the signal is sent by the return-to-zero code. After the chip is powered on and reset, it accepts the data from DIN. After receiving enough 24Bit, the DOUT end starts to forward the data to provide input data for the next chip. The DOUT port is always pulled low before forwarding, and the chip does not accept new data at this time. The three PWM output ports of the chip OUTR, OUTG and OUTB send out corresponding signals with different duty ratios according to the received 24Bit data, and the signal period is 4MS. If the input signal of the DIN terminal is the RESET signal, the chip will send the received data to the display, the chip will re-accept new data after the signal ends, and forward the data through the DOUT port after receiving the first 24Bit data. Before the RESET signal, the original output of OUTR, OUTG and OUTB remains unbounded.

After receiving a low-level RESET code of more than 80us, the chip will receive 24Bit PWM data pulse width and output it to OUTR, OUTG, OUTB

Using automatic shaping and forwarding technology, the number of cascades of the chip is not limited by signal transmission, but only limited by the speed of screen refresh. For example, we design a 1024 cascade, and its screen refresh time is $1024 \times 0.4 \times 2 = 0.8192\text{ms}$ (The data delay time of the chip is $0.4 \mu\text{s}$), and there will be no flickering phenomenon.



Part Number	Dice Material	Emitted Color	Lens Color
E6Z3535RGBC4-D04HA-1.00H-RGB04	AlGaInP-InGaN-InGaN	Red-Green-Blue	Water Clear or Diffused

Product size (Unit:mm)

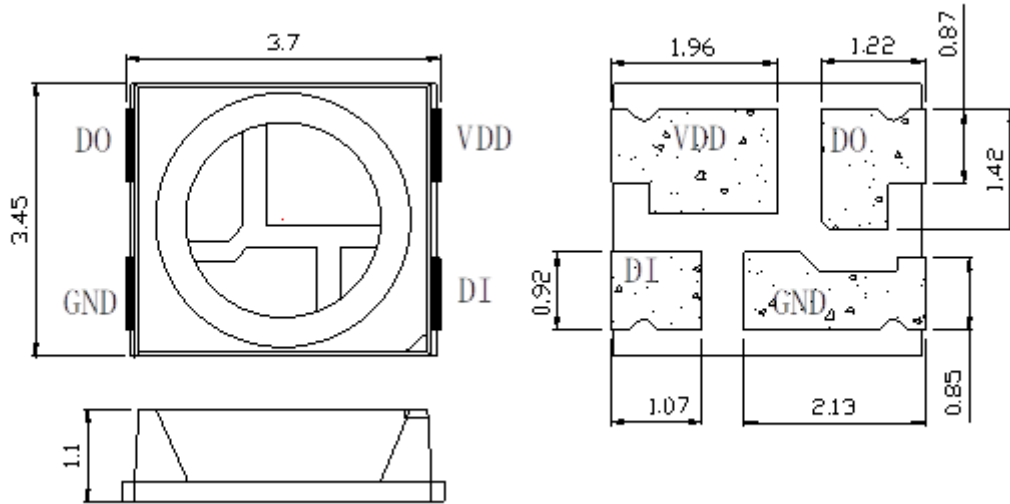

PIN function

1	VDD	Power supply LED
2	DO	Control data signal output
3	GND	Ground
4	DIN	Control data signal input

Electro-Optical Characteristics($T_a=25^{\circ}C$, @12mA)

	Color	Symbol	Min.	Typ.	Max.	Unit
Luminous Intensity	■	IV	200	-	800	mcd
	■		700	-	1800	
	■		200	-	500	
Radiation Bandwidth	■	$\Delta\lambda$	-	20	-	nm
	■		-	30	-	
	■		-	25	-	
Forward Voltage	■	VF	1.80	-	2.40	v
	■		2.80	-	3.40	
	■		2.80	-	3.40	
Dominant Wavelength	■	λ_d	620	-	635	nm
	■		520	-	535	
	■		460	-	475	
Viewing Angle	-	$2\theta_{1/2}$	-	120	-	deg
Reverse Current	-	IR	-	-	10	uA



Optical & Electrical Characteristics

Relative Intensity vs.Wavelength

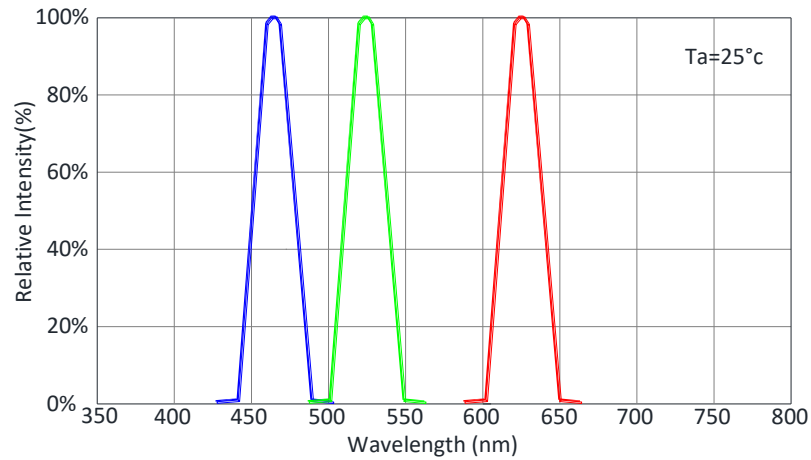

Forward Current vs.Forward Voltage

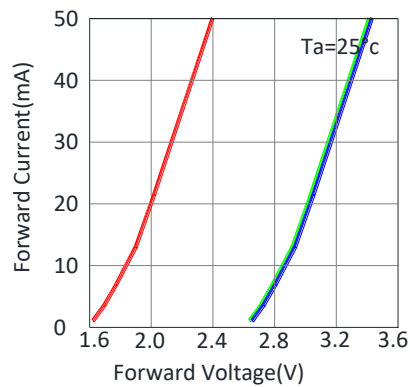

Forward Current vs.Ambient Temperature

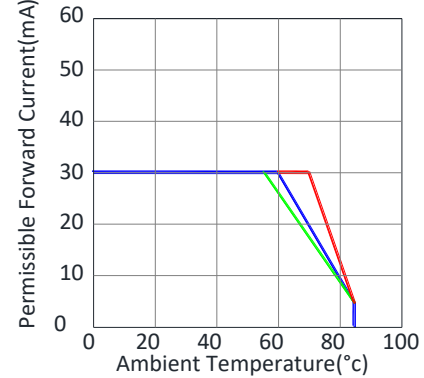

Relative Intensity vs.Forward Current

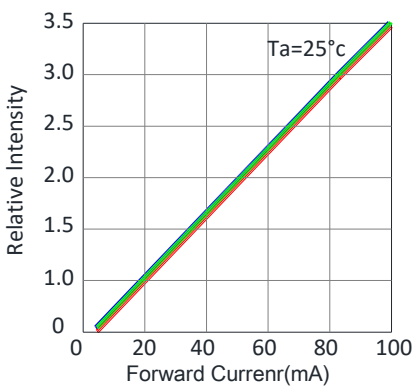

Relative Intensity vs.Ambient Temperature

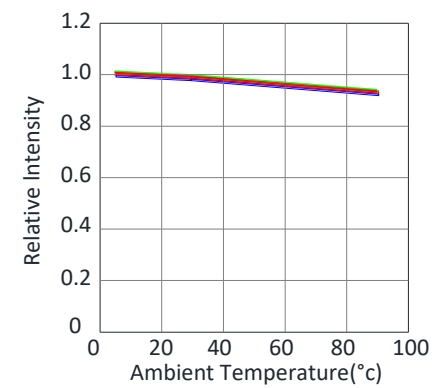

Radiation Pattern

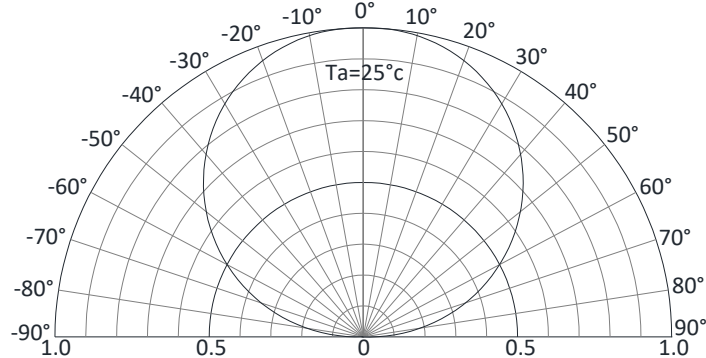

Absolute Maximum Ratings(unless otherwise specified, VDD=5 V, Ta=25 °C)

Parameter	Symbol	Ratings	Unit
Logical Power Voltage	Vin	+3.5~+7.5	V
RGB output port withstand voltage	Vds	7.5	V
Logical Input Voltage	V1	-0.5~ Vdd+0.5	V
RGB Output Current	Iol1	12	mA
Operating Temperature Range	Topr	-40to+85	°C
Storage Temperature Range	Tstg	-40to+85	°C
Operating life(rated operation conditions)	EOL	30000-50000	hour
Electrostatic Discharge	ESD	2000	V

Electrical parameters (unless otherwise specified ,Ta=25°C)

Parameter	Symbol	Min.	Typ.	Max.	Unit
input voltage	Vin	3.5	5.0	7.5	V
High level input voltage	Vih	0.7Vdd	-	-	V
Low level input	Vil	-	-	0.3Vdd	V
PWM frequency	Fpwm	-	4.0	-	Khz
Static power consumption	Ldd	-	0.3	-	mA

Switching Characteristics(unless otherwise specified ,Ta=25°C)

Parameter	Symbol	Min.	Typ.	Max.	Unit	Condition
transmission delay time	t _{PLZ}	-	-	500	ns	-
data transfer rate	F _{DIN}	-	800	1100	Khz	-

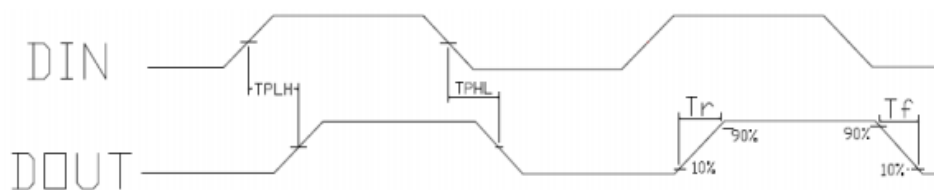
Encoding description:

The protocol uses a unipolar return-to-zero code, and each symbol must have a low level. Each symbol of this protocol starts with a high level, and the time width of the high level determines the "0" code or "1".



Data transfer time:

T	Symbol period	Min.	Typ.	Max.	Unit
T0H	0 Codes, High level time	0.250	0.295	0.380	μs
T1H	1 Code, High level time	0.510	0.595	0.700	
T0L	0 Codes, Low level time	0.510	0.595	0.700	
T1L	1 Code, Low level time	0.250	0.295	0.380	
RES	Frame units, low-level time	≥80			

Note

1. When writing a program, the minimum requirement for the symbol period is 0.9μs;
 2. The high-level time of code 0 and code 1 should be within the range specified in the above table, and the low-level time of code 0 and code 1 should be less than 15μs;
 3. Protocol data format:
- Trst+1st chip 24bits data+2nd chip 24bits data+.....+Nth chip 24bits data+Trst 24bit grayscale data structure: high bit
4. High order first, send data in the order of GRB

Sequence chart:

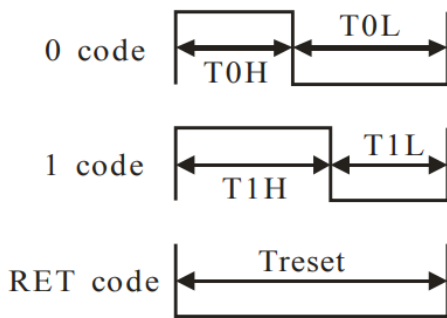

Cascade method:

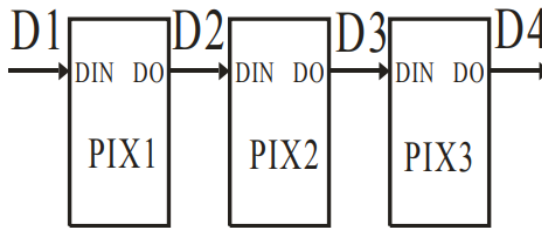

Data transmission method:

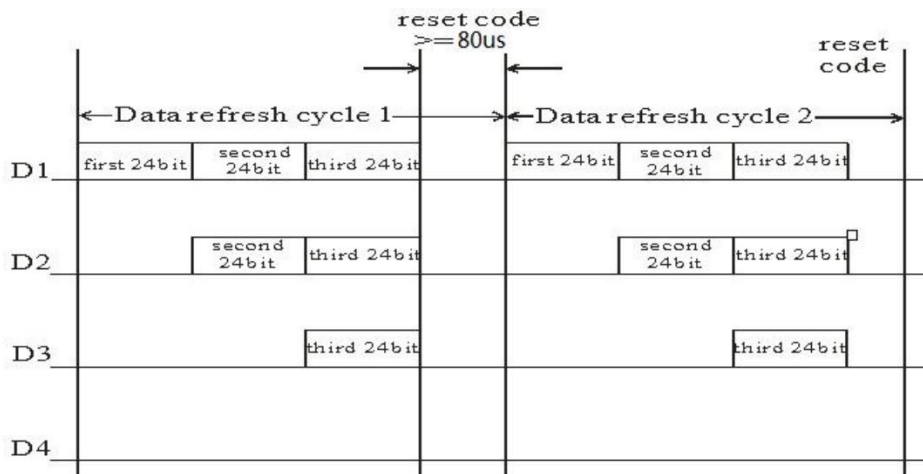

Note: The data of D1 is send by MCU, and D2, D3, D4 through pixel internal reshaping amplification to transmit

Composition of 24bit data:

G7	G6	G5	G4	G3	G2	G1	G0	R7	R6	R5	R4	R3	R2	R1	R0	B7	B6	B5	B4	B3	B2	B1	B0
----	----	----	----	----	----	----	----	----	----	----	----	----	----	----	----	----	----	----	----	----	----	----	----

Note: Follow the order of GRB to sent data and the high bit sent at first.

Typical application circuit:

1. No capacitor resistor circuit diagram

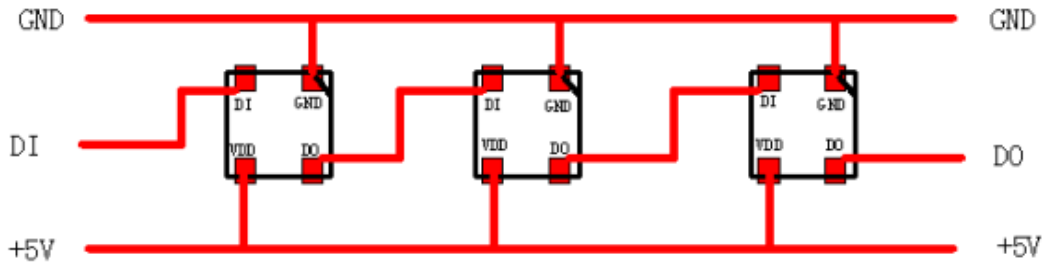

2. Circuit diagram of adding capacitors

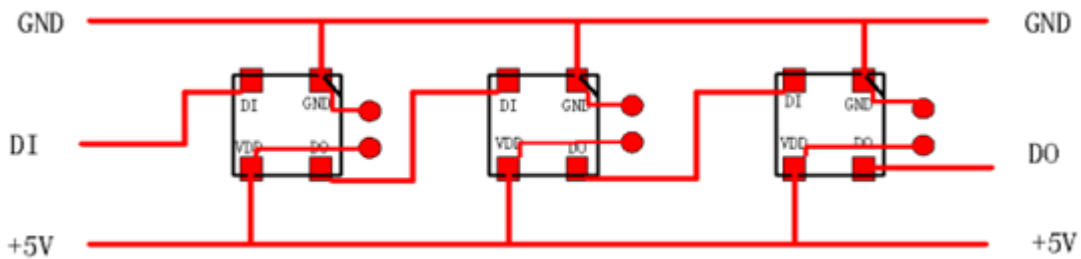

Note:

1. The capacitor is conventionally connected to a 104 chip capacitor
2. Red is the circuit and the pad, the capacitor acts as a filter, and the patch is attached according to the position of the LED gap.
3. If the line needs to be changed, adjust it according to the pin position

Taping and package Spec

•Tape Specification:4,000pcs Per Reel

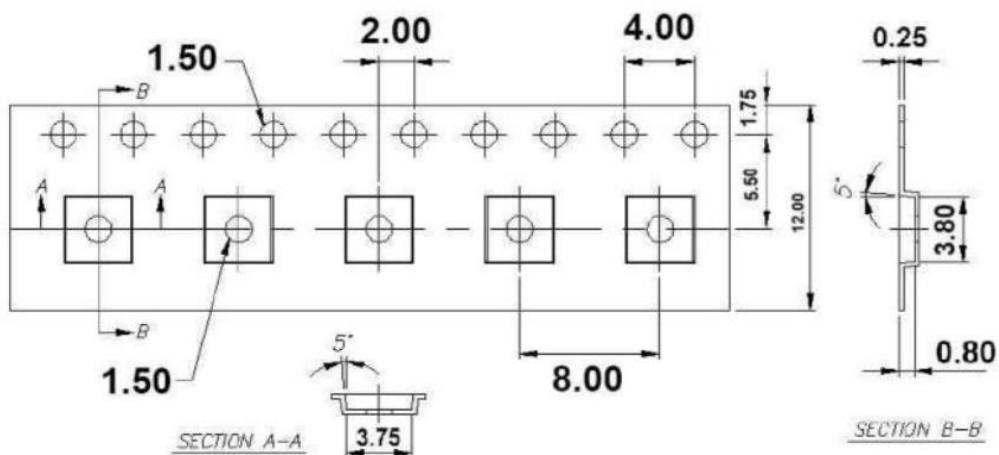

Packaging

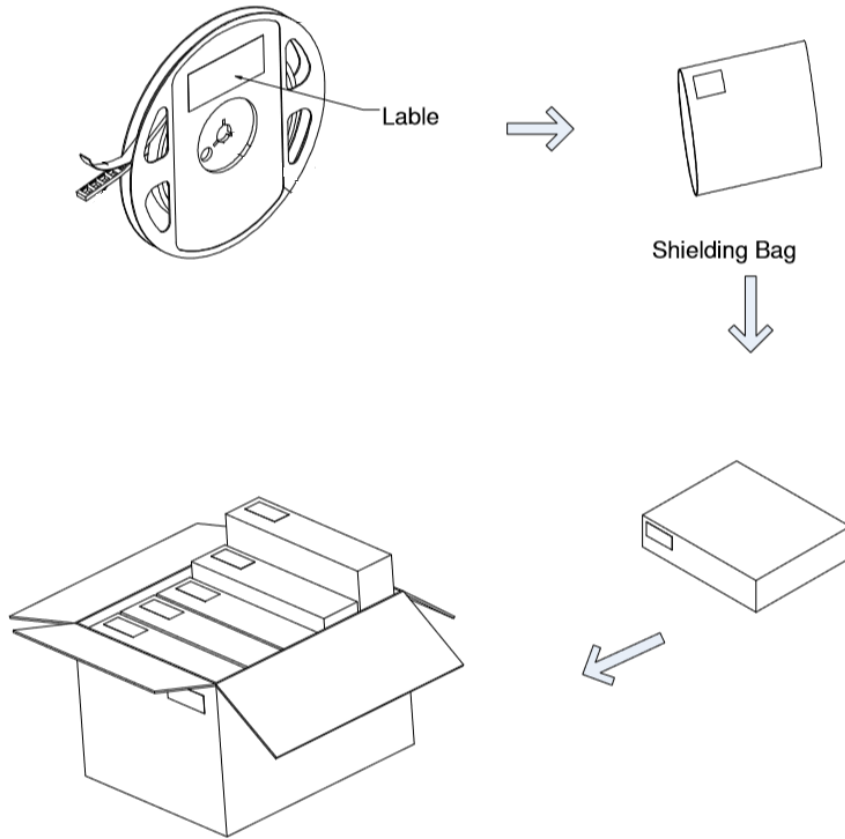

LabelStyle

EKIINGLUX OPTOELECTRONICS(SHANGHAI) CO.,LTD
 TEL:86 21 59909181 Sales@ekingluxs.com

 P/N:XXXXXXXXXXXXXXXXXX

Emitting Color: XXXX
 HUE: XXX-XXX nm
 IV : XXX-XXX mcd **example**

VF: XX-XX V BIN Code: XX
 QTY: XX PCS DATE: XXXX/XX/XX



 LOT NO.:XXXXXXX



Table of Classification Reflow Profiles

Profile Feature	Sn-Pb Eutectic Assembly	Pb-Free Assembly
Preheat & Soak	100 °C	150 °C
Temperature min (T _{smin})	150°C	200 °C
Temperature max (T _{smax})	60-120 seconds	60-120 seconds
Time (T _{smin} to T _{smax}) (t _s)		
Average ramp-up rate (T _{smax} to T _p)	3 °C/second max	3 °C/second max
Liquidous temperature (T _L)	183 °C	217 °C
Time at liquidous (t _L)	60-150 seconds	60-150 seconds
Peak package body temperature (T _p)*	230 °C ~235 °C	255 °C ~260 °C
Classification temperature (T _c)	235 °C	260 °C
Time (t _p) within 5 °C of the specified Classification temperature (T _c)	20 seconds	30 seconds
Average ramp-down rate (T _p to T _{smax})	6 °C/second max	6 °C/second max
Time 25 °C to peak temperature	6 minutes max	8 minutes max

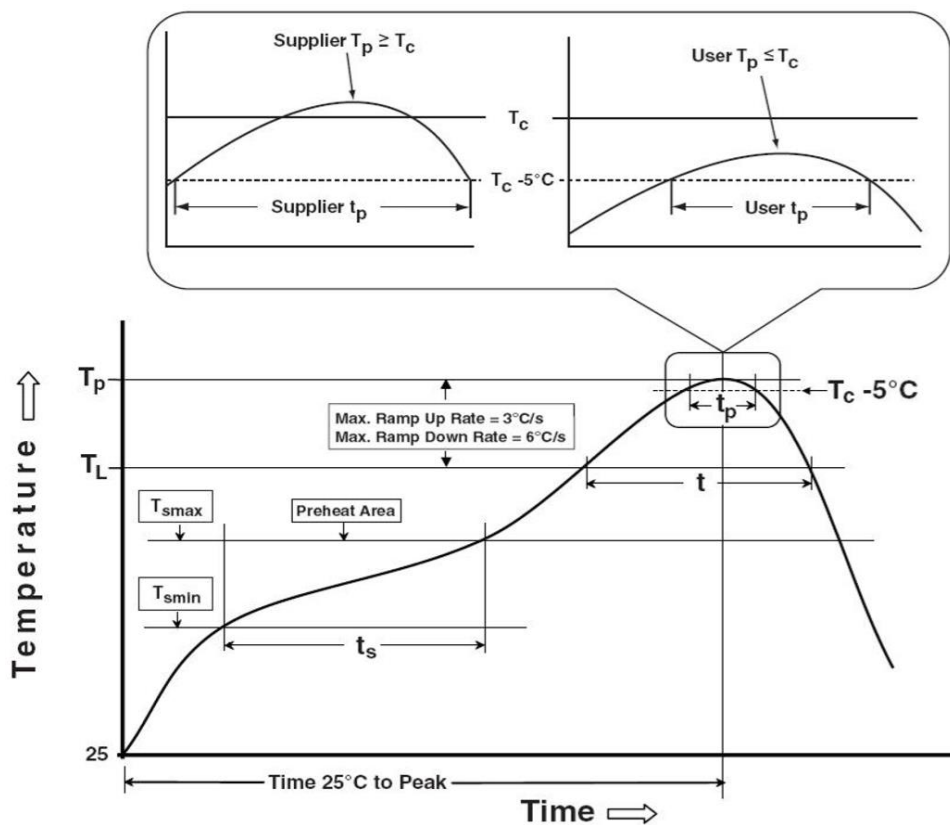
1. Tolerance for peak profile temperature (T_p) is defined as a supplier minimum and a user maximum.
2. Tolerance for time at peak profile temperature (t_p) is defined as a supplier minimum and a user maximum.



Precautions

1. Storage:

- Moisture proof and anti-electrostatic package with moisture absorbent material is used, to keep moisture to a minimum.
- Before opening the package, the product should be kept at 30°C or less and humidity less than 60% RH, and be used within a year.
- After opening the package, the product should be stored at 30°C or less and humidity less than 10%RH, and be soldered within 24 hours (1day). It is recommended that the product be operated at the workshop condition of 30°C or less and humidity less than 60%RH.
- If the moisture absorbent material has faded away or the LEDs have exceeded the storage time, baking treatment should be performed based on the following condition: (70±5)°C for 24 hours.



2. Static Electricity:

Static electricity or surge voltage damages the LEDs. Damaged LEDs will show some unusual characteristics such as the forward voltage becoming lower, or the LEDs do not light at the low current, even not light.

All devices, equipment and machinery must be properly grounded. At the same time, it is recommended that wrist bands or anti-electrostatic gloves, anti-electrostatic containers be used when dealing with the LEDs.

3. Vulcanization:

LED curing is due to sulfur being in brackets and the +1 price of silver in the chemical reaction generated Ag₂S in the process. It will lead to the capacity of reflecting of silver layer reducing, light color temperature drift and serious decline, seriously affecting the performance of the product. So we should take corresponding measures to avoid vulcanization, such as to avoid using sulphur volatile substances and keeping away from high sulphur content of the material.