



# LIGHT EMITTING DIODE SPECIFICATION

DESCRIPTION:	E6C0805-PTB
REVISION:	V2.2
ISSUE DATE:	2022-12-29

Contains trade secret information which is the property of Ekinglux and shall not be made available to, or copied or used by anyone outside Ekinglux without its written authorization. Copyright © 2017 Ekinglux Optoelectronics Technology Co., Ltd. All rights reserved

**Features:**

- Fast response time
- High photo sensitivity
- Small junction capacitance
- Pb free
- The product itself will remain within RoHS compliant version

**Application:**

- Miniature switch
- Counters and sorter
- Position sensor
- Infrared applied system
- Encoder

Part Number	Dice Material	Emitted Color	Lens Color
E6C0805-PTB	Silicon	Phototransistor	Black

**Electro-Optical Characteristics**( $T_a=25^{\circ}\text{C}$ )

Paramete	Symbol	Condition	Min.	Typ.	Max.	Unit
Collector – Emitter Breakdown Voltage	$BV_{CEO}$	$I_C=100\mu\text{A}$ $E_e=0\text{mW}/\text{cm}^2$	30	--	--	V
Emitter-Collector Breakdown Voltage	$BV_{ECO}$	$I_E=100\mu\text{A}$ $E_e=0\text{mW}/\text{cm}^2$	5	--	--	V
Collector-Emitter Saturation Voltage	$V_{CE(sat)}$	$I_C=2\text{mA}$ $E_e=1\text{mW}/\text{cm}^2$	--	--	0.4	V
Rise Time	$t_r$	$V_{CE}=5\text{V}$ $I_C=1\text{mA}$ $R_L=1000\Omega$	--	15	--	$\mu\text{S}$
Fall Time	$t_f$	$V_{CE}=5\text{V}$ $I_C=1\text{mA}$ $R_L=1000\Omega$	--	15	--	$\mu\text{S}$
Collector Dark Current	$I_{CEO}$	$E_e=0\text{mW}/\text{cm}^2$ $V_{CE}=20\text{V}$	--	--	100	nA
On State Collector Current	$I_{C(ON)}$	$E_e=1\text{mW}/\text{cm}^2$ $V_{CE}=5\text{V}$	2.0	3.0	--	mA
Rang Of Spectral Bandwidth	$\lambda_{0.5}$	--	730	--	1100	nm
Wavelength of Peak Sensitivity	$\lambda_p$	--	--	940	--	nm

**Absolute Maximum Ratings**( $T_a=25^{\circ}\text{C}$ )

Parameter	Symbol	Ratings	Unit
Power Dissipation at(or below) 25 Free Air Temperature	Pd	75	mW
Collector-Emitter Voltage	$V_{\text{CEO}}$	30	V
Emitter-Collector-Voltage	$V_{\text{ECO}}$	5	V
Collector Current	$I_{\text{c(ON)}}$	20	mA
Operating Temperature	Topr	-40~+85	$^{\circ}\text{C}$
Storage Temperature	Tstg	-40~+90	$^{\circ}\text{C}$
Lead Soldering Temperature (2mm form body for 5 seconds)	Tsol	260	$^{\circ}\text{C}$

**Rank**

Parameter	Symbol	Condition	Min.	Max.	Unit
BIN2	$I_{\text{c(ON)}}$	$E_e=1\text{mW}/\text{cm}^2$ $V_{\text{CE}}=5\text{V}$	2.0	3.0	mA
BIN3	$I_{\text{c(ON)}}$	$E_e=1\text{mW}/\text{cm}^2$ $V_{\text{CE}}=5\text{V}$	3.0	4.0	mA
BIN4	$I_{\text{c(ON)}}$	$E_e=1\text{mW}/\text{cm}^2$ $V_{\text{CE}}=5\text{V}$	4.0	5.0	mA
BIN5	$I_{\text{c(ON)}}$	$E_e=1\text{mW}/\text{cm}^2$ $V_{\text{CE}}=5\text{V}$	-	-	mA



### Optical & Electrical Characteristics

Fig.1 Collector Power Dissipation vs. Ambient Temperature

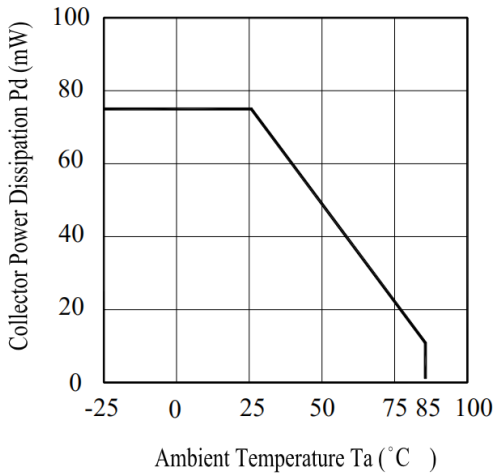

Fig.2 Spectral Sensitivity

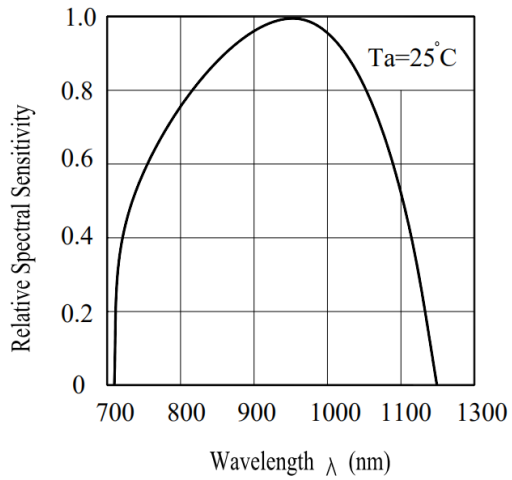

Fig.3 Relative Collector Current vs. Ambient Temperature

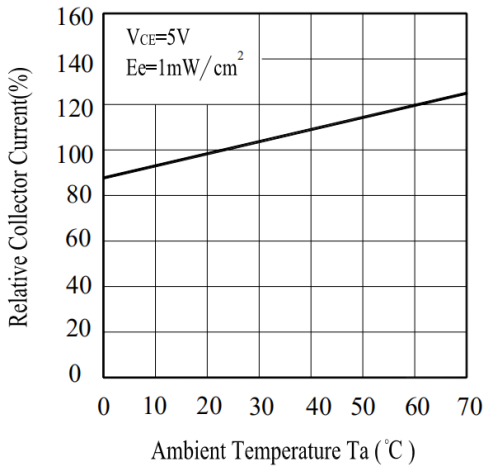

Fig.4 Collector Current vs. Irradiance

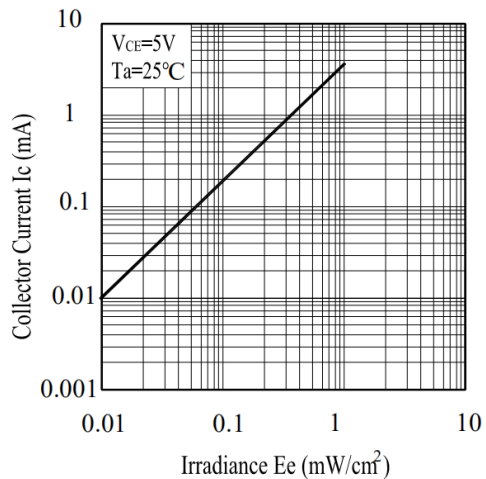

Fig.5 Collector Dark Current vs. Ambient Temperature

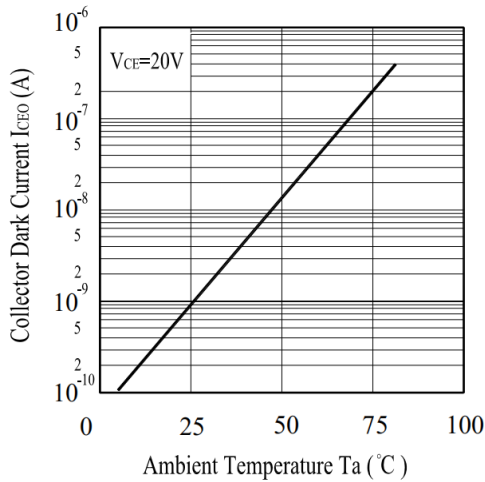
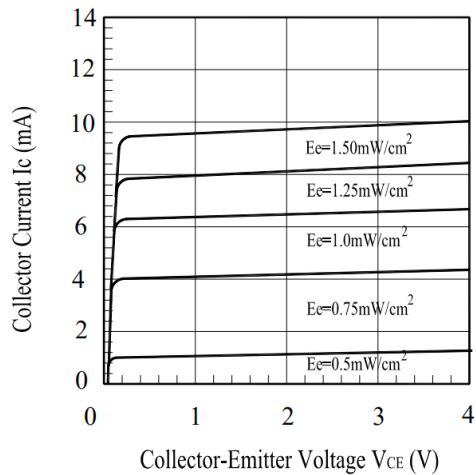

Fig.6 Collector Current vs. Collector-Emitter Voltage



**Reliability Test Items And Conditions**

Test Items	Reference	Test Conditions	Time	Quantity	Criterion
Thermal Shock	MIL-STD-202G	-40°C (30min) -100°C (30min)	100 Cycles	22	0/22
Temperature And Humidity Cyclic	JEITA ED-4701 200 203	-10°C~65°C ; 0%~90%RH	10cycles	22	0/22
High Temperature Storage	JEITA ED -4071 200 201	Ta=100°C	1000H	22	0/22
Low Temperature Storage	JEITA ED -4071 200 202	Ta=-40°C	1000H	22	0/22
High Temperature High Humidity Storage	JEITA ED -4071 100 103	Ta=60°C ; RH=90%	1000H	22	0/22
High Temperature Life Test	JESD22-A108D	Ta=80°C	1000H	22	0/22
Life Test	JESD22-A108D	Ta=25°C	1000H	22	0/22
Resistance to Soldering Heat	GB/T 4937, II , 2.2&2.3	Tsol*=(240±5) °C 10secs	2 times	22	0/22

**Criteria For Judging Damage**

Test Items	Symbol	Test Conditions	Criteria For Judging Damage
Forward Voltage	V <sub>F</sub>	I <sub>F</sub> =I <sub>FT</sub>	Initial Data±10%
Reverse Current	I <sub>R</sub>	V <sub>R</sub> =5V	I <sub>R</sub> ≤10uA
Luminous Intensity	I <sub>V</sub>	I <sub>F</sub> =I <sub>FT</sub>	Average I <sub>V</sub> degradation≤30% ; Single LED I <sub>V</sub> degradation≤50%
Resistance to Soldering Heat	-	-	Material without internal cracks,no material between stripped,no dead light

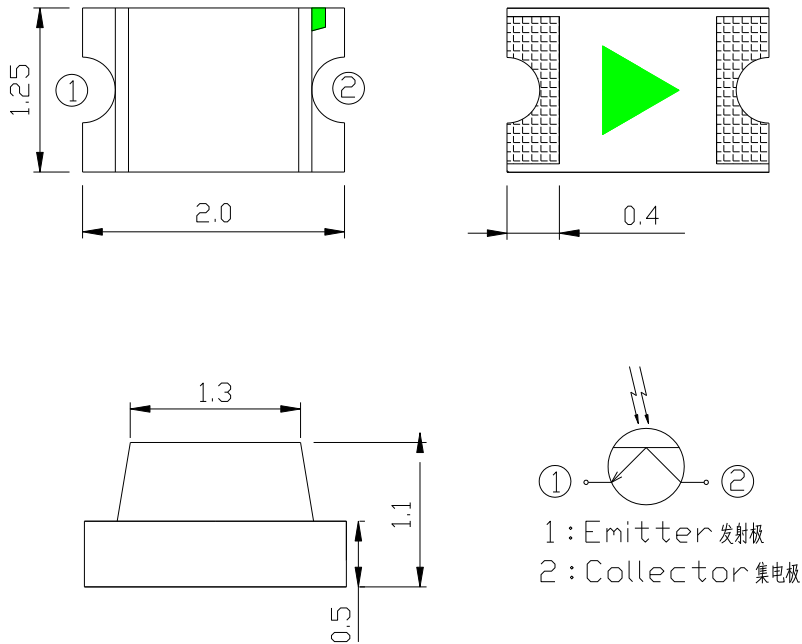
**Product size (Unit:mm)**

**NOTES :**

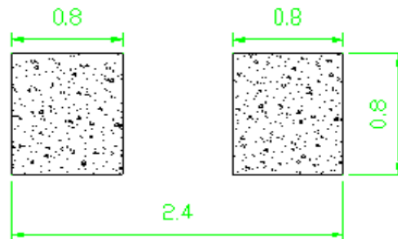
1. All dimensions are in millimeters (inches)
2. Tolerances are  $\pm 0.2\text{mm}$  (0.008inch) unless otherwise noted

**Recommended Soldering Pad Design (Unit:mm)**

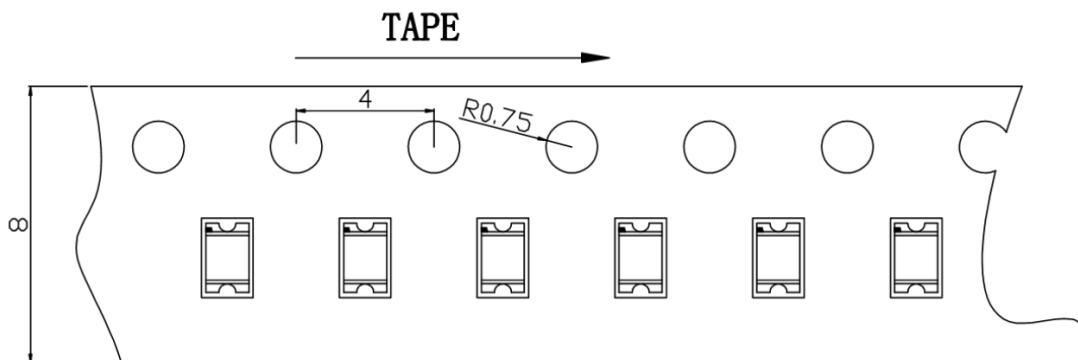
**Taping and package Spec**

- Tape Specification:3,000pcs Per Reel



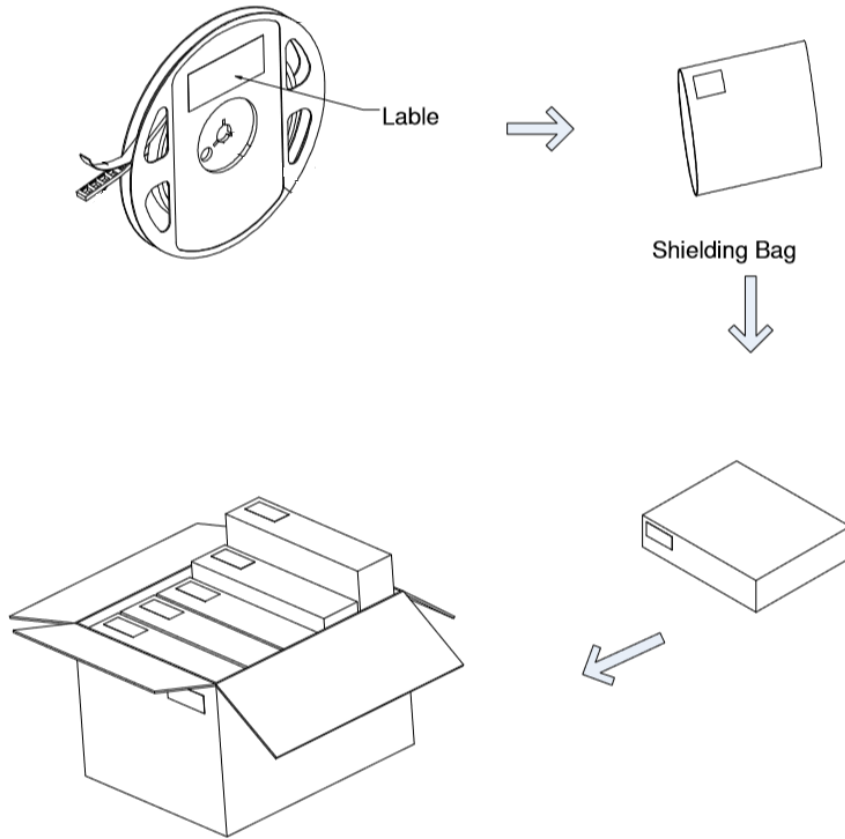

### Packaging



### LabelStyle

EKINGLUX OPTOELECTRONICS(SHANGHAI) CO.,LTD  
 TEL:86 21 59909181      Sales@ekingluxs.com



P/N:XXXXXXXXXXXXXXXXXX

Emitting Color: XXXX  
 HUE: XXX-XXX nm  
 IV : XXX-XXX mcd **example**  
 VF: XX-XX V  
 QTY: XX PCS

**RoHS COMPLIANT** **Pb Pb-Free**

BIN Code: XX  
 DATE: XXXX/XX/XX



LOT NO.:XXXXXXX

### Table of Classification Reflow Profiles

Profile Feature	Sn-Pb Eutectic Assembly	Pb-Free Assembly
Preheat & Soak	100 °C	150 °C
Temperature min (T <sub>smin</sub> )	150°C	200 °C
Temperature max (T <sub>smax</sub> )	60-120 seconds	60-120 seconds
Time (T <sub>smin</sub> to T <sub>smax</sub> ) (t <sub>s</sub> )		
Average ramp-up rate (T <sub>smax</sub> to T <sub>p</sub> )	3 °C/second max	3 °C/second max
Liquidous temperature (T <sub>L</sub> )	183 °C	217 °C
Time at liquidous (t <sub>L</sub> )	60-150 seconds	60-150 seconds
Peak package body temperature (T <sub>p</sub> )*	230 °C ~235 °C	255 °C ~260 °C
Classification temperature (T <sub>c</sub> )	235 °C	260 °C
Time (t <sub>p</sub> ) within 5 °C of the specified Classification temperature (T <sub>c</sub> )	20 seconds	30 seconds
Average ramp-down rate (T <sub>p</sub> to T <sub>smax</sub> )	6 °C/second max	6 °C/second max
Time 25 °C to peak temperature	6 minutes max	8 minutes max

1. Tolerance for peak profile temperature (T<sub>p</sub>) is defined as a supplier minimum and a user maximum.
2. Tolerance for time at peak profile temperature (t<sub>p</sub>) is defined as a supplier minimum and a user maximum.

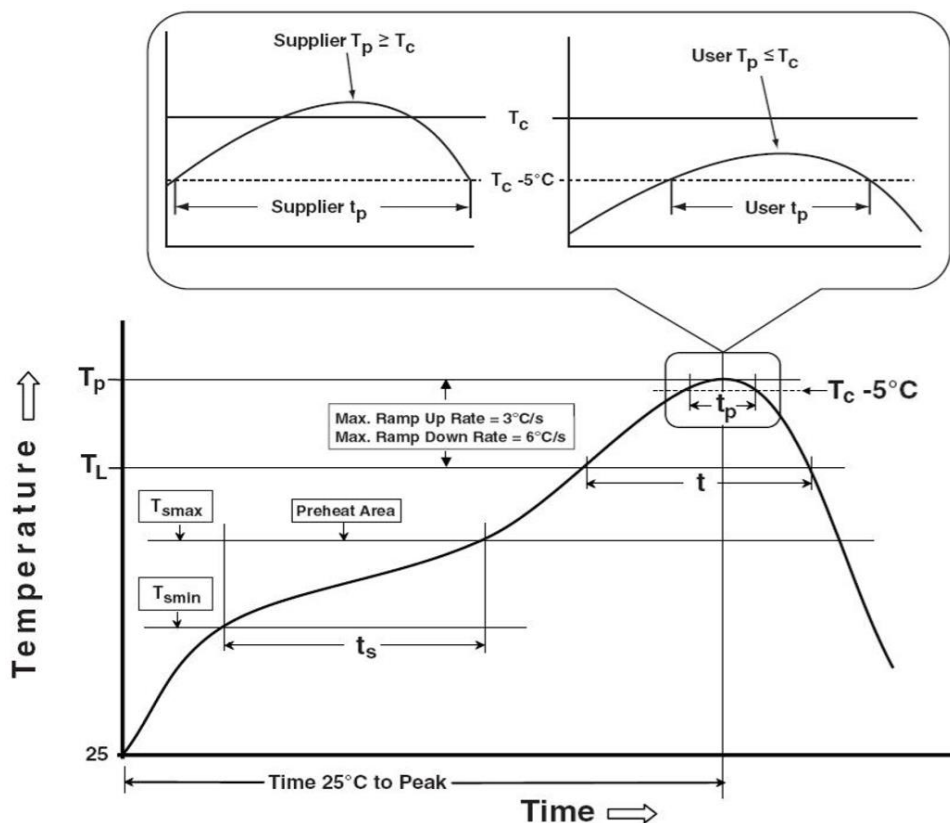



## Precautions

### 1. Storage:

- Moisture proof and anti-electrostatic package with moisture absorbent material is used, to keep moisture to a minimum.
- Before opening the package, the product should be kept at 30°C or less and humidity less than 60% RH, and be used within a year.
- After opening the package, the product should be stored at 30°C or less and humidity less than 10%RH. It is recommended that the product be operated at the workshop condition of 30°C or less and humidity less than 60%RH.
- If the moisture absorbent material has faded away or the LEDs have exceeded the storage time, baking treatment should be performed based on the following condition: (70±5)°C for 24 hours.

### 2. Static Electricity:

Static electricity or surge voltage damages the LEDs. Damaged LEDs will show some unusual characteristics such as the forward voltage becoming lower, or the LEDs do not light at the low current, even not light.

All devices, equipment and machinery must be properly grounded. At the same time, it is recommended that wrist bands or anti-electrostatic gloves, anti-electrostatic containers be used when dealing with the LEDs.

### 3. Vulcanization:

LED curing is due to sulfur being in brackets and the +1 price of silver in the chemical reaction generated Ag<sub>2</sub>S in the process. It will lead to the capacity of reflecting of silver layer reducing, light color temperature drift and serious decline, seriously affecting the performance of the product. So we should take corresponding measures to avoid vulcanization, such as to avoid using sulphur volatile substances and keeping away from high sulphur content of the material.