



# LIGHT EMITTING DIODE SPECIFICATION

|              |                |
|--------------|----------------|
| DESCRIPTION: | E6T3535 series |
| REVISION:    | V2.2           |
| ISSUE DATE:  | 2019-01-18     |

Contains trade secret information which is the property of Ekinglux and shall not be made available to, or copied or used by anyone outside Ekinglux without its written authorization. Copyright © 2017 Ekinglux Optoelectronics Technology Co., Ltd. All rights reserved

**Features:**

- Long operating life
- Super thermal ceramic bracket
- Leading eutectic flip chip process
- Super high Flux output and high Luminance
- Wide Viewing Angle
- RoHS Compliant

**Application:**

- Caution light
- Decoration lighting
- Automobile lamps
- Indicator
- outdoor lighting

| Part Number     | Dice Material | Emitted Color | CCT(k)    | Lens Color  |
|-----------------|---------------|---------------|-----------|-------------|
| E6T3535WWAY1UDA | InGaN         | Warm White    | 2700-3500 | Water Clear |
| E6T3535NWAY1UDA |               | Natural White | 3800-4500 |             |
| E6T3535CWAY1UDA |               | Cool White    | 5000-7000 |             |

**Electro-Optical Characteristics** (Ta=25°C)

| Parameter             | Symbol | Min. | Typ. | Max. | Unit | Condition |
|-----------------------|--------|------|------|------|------|-----------|
| Luminous Flux         | Φ      | 120  | -    | 180  | Lm   | IF=350mA  |
|                       |        | 240  | -    | 280  | Lm   | IF=700mA  |
| Forward Voltage       | VF     | 2.90 | 3.00 | 3.40 | v    | IF=350mA  |
| Color Rendering index | CRI    | 70   | 80   | 90   | %    |           |
| CIE Coordinates CIE   | x,y    | -    | -    | -    | -    |           |
| Color Temperature     | Tc     | 2700 | 4000 | 7000 | k    |           |
| Viewing Angle         | 2θ1/2  | -    | 120  | -    | deg  |           |
| Reverse Current       | IR     | -    | -    | 10   | uA   | Vr=5v     |

**Absolute Maximum Ratings** (Ta=25°C)

| Parameter  | Symbol | Max.             | Unit |
|--|--------|------------------|------|
| Peak Forward Current(1/10 Duty Cycle, 0.1ms Pulse Width) | IFP    | 1000             | mA   |
| Forward Current  | IF     | 700              | mA   |
| Reverse Voltage  | VR     | 5                | v    |
| Operating Temperature Range                              | Topr   | -40to+85         | °C   |
| Storage Temperature Range                                | Tstg   | -40to+90         | °C   |
| Reflow Soldering   | Tsld   | 260°C for 10secs |      |

## Optical & Electrical Characteristics

Figure 1:Wavelength Characteristics

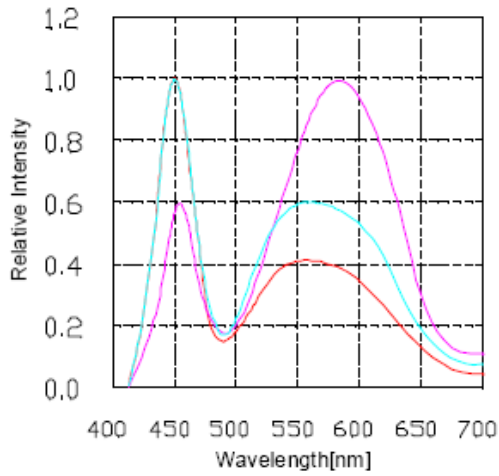

Figure 2:Forward Current vs. Forward Voltage

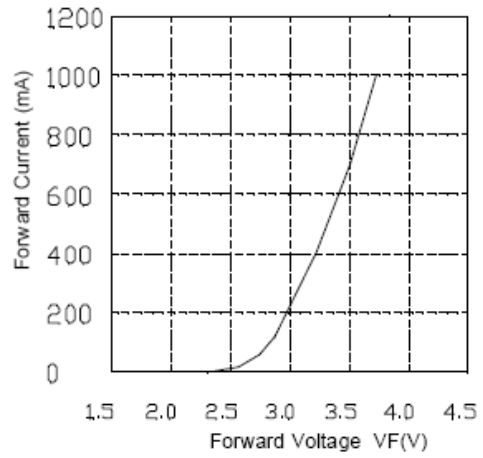

Figure 3:Forward Current vs. Temperature

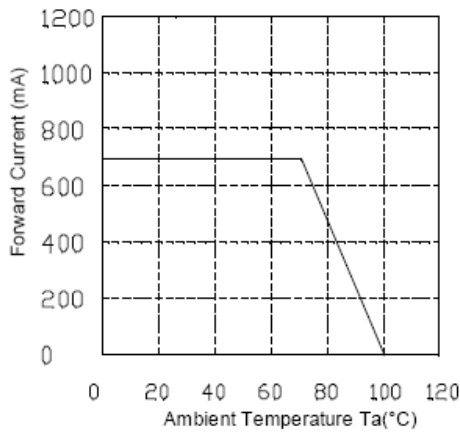

Figure 4:Relative Luminous Flux vs. Forward Current

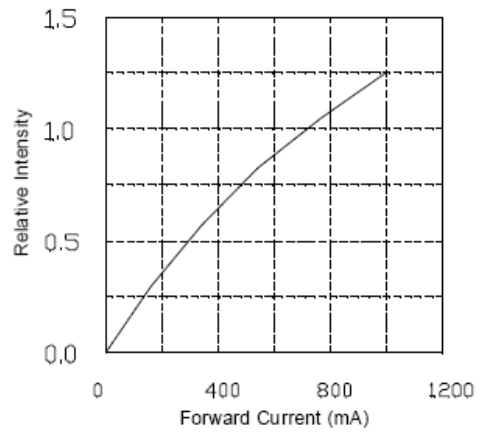

Figure 5: Relative Luminous Flux vs. Temperature

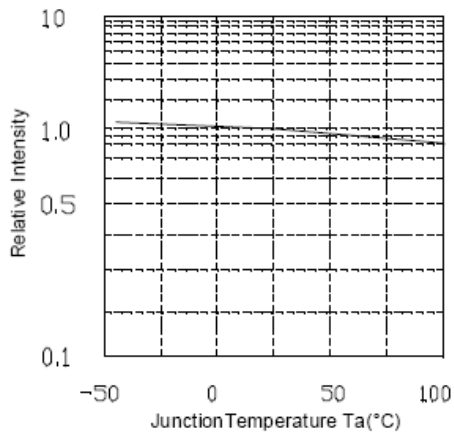
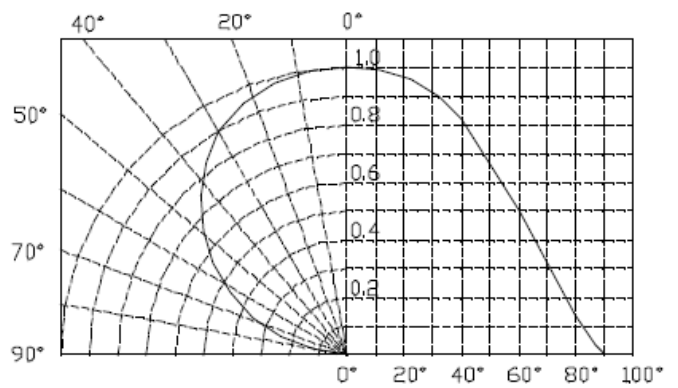

Figure 6: Radiation Pattern



## Bin Limits

### Bin Range Of Luminous Intensity (Unit:lm)

| Bin Code | Min | Max | Condition |
|----------|-----|-----|-----------|
| L1       | 120 | 130 | IF=350mA  |
| L2       | 130 | 140 |           |
| L3       | 140 | 150 |           |
| L4       | 150 | 160 |           |
| L5       | 160 | 170 |           |
| L6       | 170 | 180 |           |

### Bin Range Of Forward Voltage (Unit:V)

| Bin Code | Min | Max | Condition |
|----------|-----|-----|-----------|
| V1       | 2.9 | 3.0 | IF=350mA  |
| V2       | 3.0 | 3.1 |           |
| V3       | 3.1 | 3.2 |           |
| V4       | 3.2 | 3.3 |           |
| V5       | 3.3 | 3.4 |           |

Notes:

- 1.Tolerance of Luminous Intensity  $\pm 10\%$
- 2.Tolerance of Forward Voltage  $\pm 0.1V$



### CIE Chromaticity Diagram@ Warm White

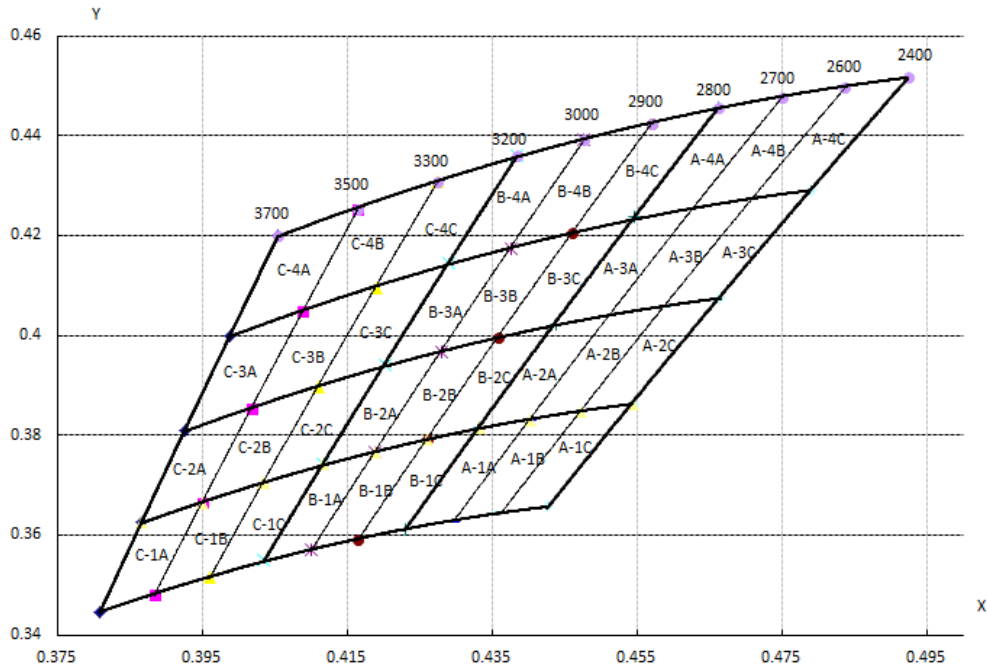

### Color Bin Limits

| Code | X1     | Y1     | X2     | Y2     | X3     | Y3     | X4     | Y4     |
|------|--------|--------|--------|--------|--------|--------|--------|--------|
| A-4A | 0.4662 | 0.4457 | 0.4547 | 0.4236 | 0.4628 | 0.4254 | 0.4750 | 0.4477 |
| A-3A | 0.4547 | 0.4236 | 0.4438 | 0.4023 | 0.4513 | 0.4040 | 0.4628 | 0.4254 |
| A-2A | 0.4438 | 0.4023 | 0.4332 | 0.3815 | 0.4403 | 0.3831 | 0.4513 | 0.4040 |
| A-1A | 0.4332 | 0.3815 | 0.4230 | 0.3612 | 0.4296 | 0.3627 | 0.4403 | 0.3831 |
| B-4C | 0.4570 | 0.4425 | 0.4461 | 0.4205 | 0.4547 | 0.4236 | 0.4662 | 0.4457 |
| B-3C | 0.4461 | 0.4205 | 0.4359 | 0.3995 | 0.4438 | 0.4023 | 0.4547 | 0.4236 |
| B-2C | 0.4359 | 0.3995 | 0.4260 | 0.3791 | 0.4332 | 0.3815 | 0.4438 | 0.4023 |
| B-1C | 0.4260 | 0.3791 | 0.4165 | 0.3591 | 0.4230 | 0.3612 | 0.4332 | 0.3815 |
| B-4B | 0.4477 | 0.4393 | 0.4376 | 0.4174 | 0.4461 | 0.4205 | 0.4570 | 0.4425 |
| B-3B | 0.4376 | 0.4174 | 0.4281 | 0.3967 | 0.4359 | 0.3995 | 0.4461 | 0.4205 |
| B-2B | 0.4281 | 0.3967 | 0.4189 | 0.3766 | 0.4260 | 0.3791 | 0.4359 | 0.3995 |
| B-1B | 0.4189 | 0.3766 | 0.4100 | 0.3571 | 0.4165 | 0.3591 | 0.4260 | 0.3791 |
| B-4A | 0.4384 | 0.4360 | 0.4290 | 0.4143 | 0.4376 | 0.4174 | 0.4477 | 0.4393 |
| B-3A | 0.4290 | 0.4143 | 0.4202 | 0.3939 | 0.4281 | 0.3967 | 0.4376 | 0.4174 |
| B-2A | 0.4202 | 0.3939 | 0.4117 | 0.3741 | 0.4189 | 0.3766 | 0.4281 | 0.3967 |
| B-1A | 0.4117 | 0.3741 | 0.4035 | 0.3550 | 0.4100 | 0.3571 | 0.4189 | 0.3766 |



### CIE Chromaticity Diagram@ Natural White

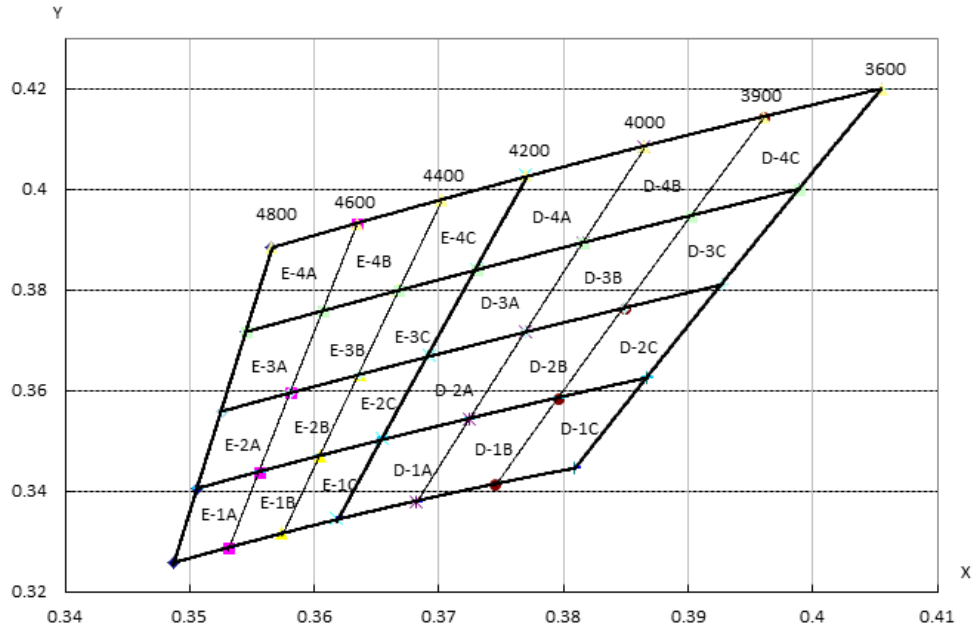

### Color Bin Limits

| Code | X1     | Y1     | X2     | Y2     | X3     | Y3     | X4     | Y4     |
|------|--------|--------|--------|--------|--------|--------|--------|--------|
| D-4C | 0.3960 | 0.4142 | 0.3903 | 0.3947 | 0.3989 | 0.4000 | 0.4055 | 0.4200 |
| D-3C | 0.3903 | 0.3947 | 0.3849 | 0.3763 | 0.3927 | 0.3810 | 0.3989 | 0.4000 |
| D-2C | 0.3849 | 0.3763 | 0.3796 | 0.3585 | 0.3867 | 0.3625 | 0.3927 | 0.3810 |
| D-1C | 0.3796 | 0.3585 | 0.3745 | 0.3412 | 0.3809 | 0.3446 | 0.3867 | 0.3625 |
| D-4B | 0.3865 | 0.4084 | 0.3816 | 0.3893 | 0.3903 | 0.3947 | 0.3960 | 0.4142 |
| D-3B | 0.3816 | 0.3893 | 0.3770 | 0.3715 | 0.3849 | 0.3763 | 0.3903 | 0.3947 |
| D-2B | 0.3770 | 0.3715 | 0.3725 | 0.3544 | 0.3796 | 0.3585 | 0.3849 | 0.3763 |
| D-1B | 0.3725 | 0.3544 | 0.3682 | 0.3379 | 0.3745 | 0.3412 | 0.3796 | 0.3585 |
| D-4A | 0.3770 | 0.4027 | 0.3730 | 0.3840 | 0.3816 | 0.3893 | 0.3865 | 0.4084 |
| D-3A | 0.3730 | 0.3840 | 0.3692 | 0.3668 | 0.3770 | 0.3715 | 0.3816 | 0.3893 |
| D-2A | 0.3692 | 0.3668 | 0.3655 | 0.3503 | 0.3725 | 0.3544 | 0.3770 | 0.3715 |
| D-1A | 0.3655 | 0.3503 | 0.3618 | 0.3345 | 0.3682 | 0.3379 | 0.3725 | 0.3544 |



### CIE Chromaticity Diagram@ Cool White

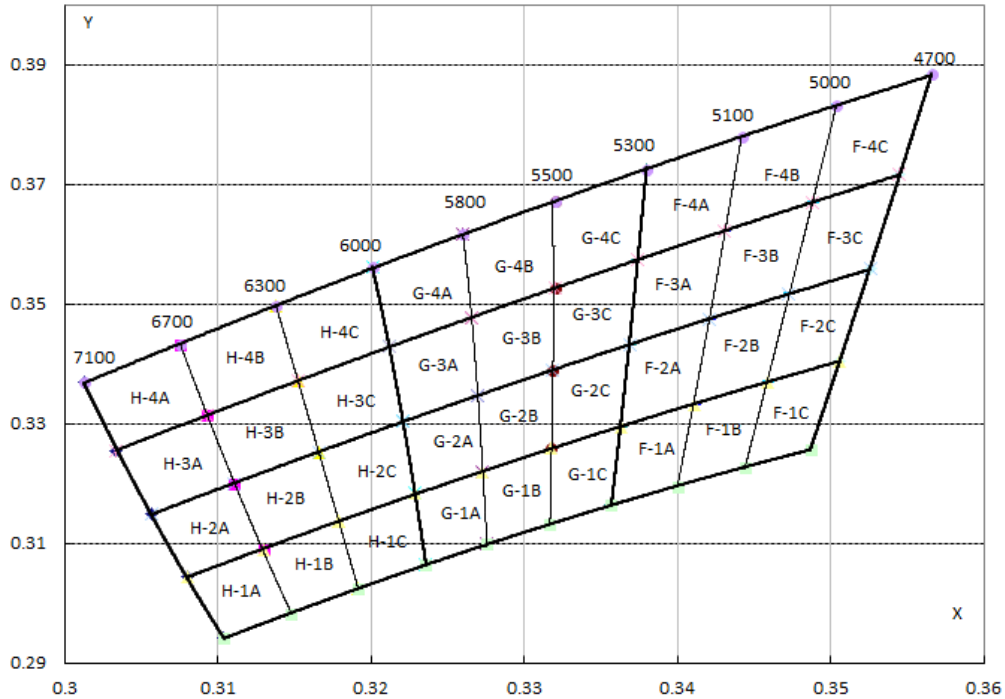

### Color Bin Limits

| Code | X1     | Y1     | X2     | Y2     | X3     | Y3     | X4     | Y4     |
|------|--------|--------|--------|--------|--------|--------|--------|--------|
| H-4C | 0.3138 | 0.3497 | 0.3153 | 0.3371 | 0.3212 | 0.3429 | 0.3201 | 0.3562 |
| H-3C | 0.3153 | 0.3371 | 0.3166 | 0.3252 | 0.3221 | 0.3304 | 0.3212 | 0.3429 |
| H-2C | 0.3166 | 0.3252 | 0.3179 | 0.3136 | 0.3229 | 0.3183 | 0.3221 | 0.3304 |
| H-1C | 0.3179 | 0.3136 | 0.3192 | 0.3024 | 0.3236 | 0.3065 | 0.3229 | 0.3183 |
| H-4B | 0.3076 | 0.3432 | 0.3093 | 0.3313 | 0.3153 | 0.3371 | 0.3138 | 0.3497 |
| H-3B | 0.3093 | 0.3313 | 0.3111 | 0.3200 | 0.3166 | 0.3252 | 0.3153 | 0.3371 |
| H-2B | 0.3111 | 0.3200 | 0.3130 | 0.3090 | 0.3179 | 0.3136 | 0.3166 | 0.3252 |
| H-1B | 0.3130 | 0.3090 | 0.3148 | 0.2982 | 0.3192 | 0.3024 | 0.3179 | 0.3136 |
| H-4A | 0.3013 | 0.3368 | 0.3034 | 0.3255 | 0.3093 | 0.3313 | 0.3076 | 0.3432 |
| H-3A | 0.3034 | 0.3255 | 0.3057 | 0.3148 | 0.3111 | 0.3200 | 0.3093 | 0.3313 |
| H-2A | 0.3057 | 0.3148 | 0.3080 | 0.3043 | 0.3130 | 0.3090 | 0.3111 | 0.3200 |
| H-1A | 0.3080 | 0.3043 | 0.3104 | 0.2941 | 0.3148 | 0.2982 | 0.3130 | 0.3090 |

**Reliability Test Items And Conditions**

| Test Items                                | Reference                  | Test Conditions                 | Time          | Quantity | Criterion |
|---|----------------------------|---------------------------------|---------------|----------|-----------|
| Thermal Shock                             | MIL-STD-202G               | -40°C (30min)<br>-100°C (30min) | 100<br>Cycles | 22       | 0/22      |
| Temperature And Humidity<br>Cyclic        | JEITA ED-4701 200<br>203   | -10°C~65°C ;<br>0%~90%RH        | 10cycles      | 22       | 0/22      |
| High Temperature Storage                  | JEITA ED -4071 200<br>201  | Ta=100°C                        | 1000H         | 22       | 0/22      |
| Low Temperature Storage                   | JEITA ED -4071 200<br>202  | Ta=-40°C                        | 1000H         | 22       | 0/22      |
| High Temperature High<br>Humidity Storage | JEITA ED -4071 100<br>103  | Ta=60°C ;<br>RH=90%             | 1000H         | 22       | 0/22      |
| High Temperature Life Test                | JESD22-A108D               | Ta=80°C                         | 1000H         | 22       | 0/22      |
| Life Test                                 | JESD22-A108D               | Ta=25°C<br>IF=350mA             | 1000H         | 22       | 0/22      |
| Resistance to Soldering<br>Heat           | GB/T 4937, II ,<br>2.2&2.3 | Tsol*=(240±5)<br>°C 10secs      | 2 times       | 22       | 0/22      |

**Criteria For Judging Damage**

| Test Items                      | Symbol         | Test Conditions                 | Criteria For Judging Damage   |
|---------------------------------|----------------|---------------------------------|---|
| Forward Voltage                 | V <sub>F</sub> | I <sub>F</sub> =I <sub>FT</sub> | Initial Data±10%  |
| Reverse Current                 | I <sub>R</sub> | V <sub>R</sub> =5V              | I <sub>R</sub> ≤10uA  |
| Luminous Intensity              | I <sub>V</sub> | I <sub>F</sub> =I <sub>FT</sub> | Average I <sub>V</sub> degradation≤30% ; Single LED I <sub>V</sub><br>degradation≤50% |
| Resistance to<br>Soldering Heat | -              | -                               | Material without internal cracks,no material<br>between stripped,no deaded light      |



### Product size (Unit:mm)

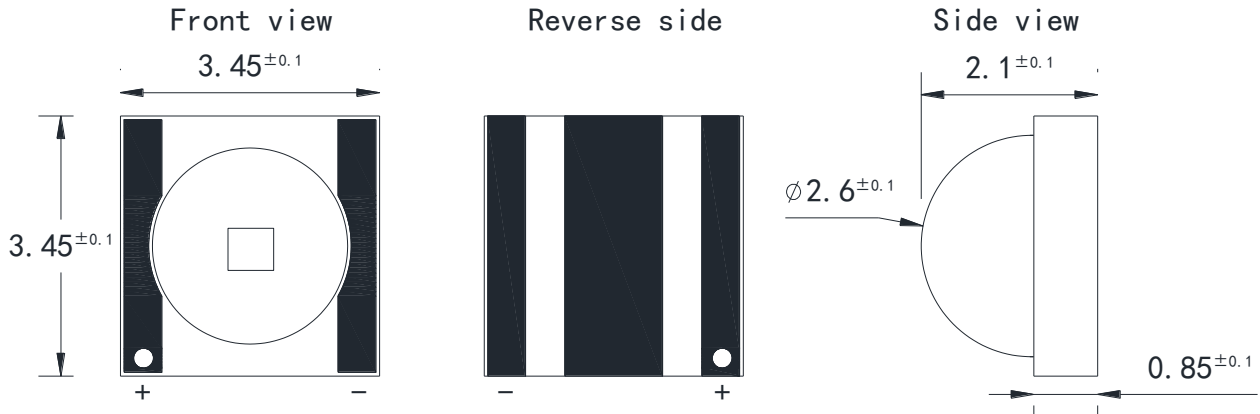

**NOTES :**

1. All dimensions are in millimeters (inches)
2. Tolerances are  $\pm 0.2$ mm (0.008inch) unless otherwise noted

### Recommended Soldering Pad Design (Unit:mm)

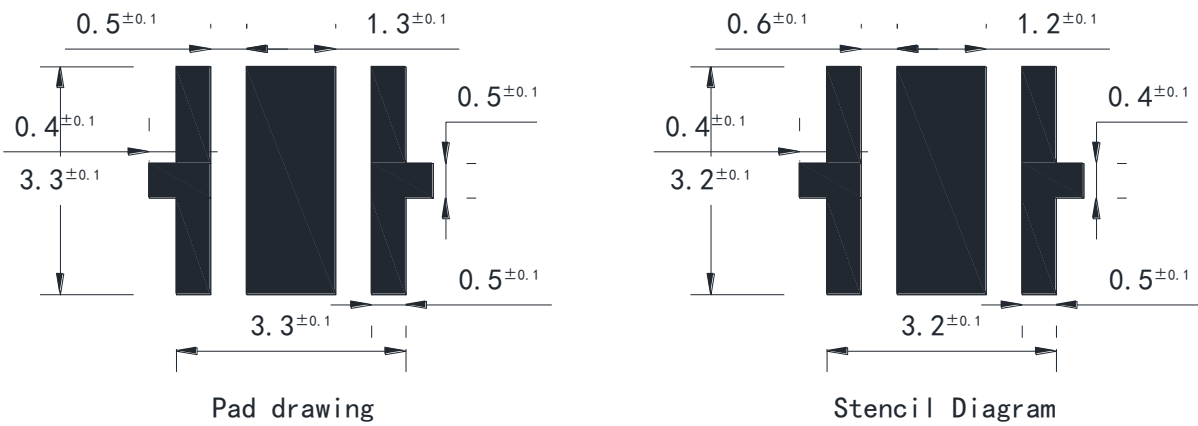

### Taping and package Spec

- Tape Specification:1,000pcs Per Reel

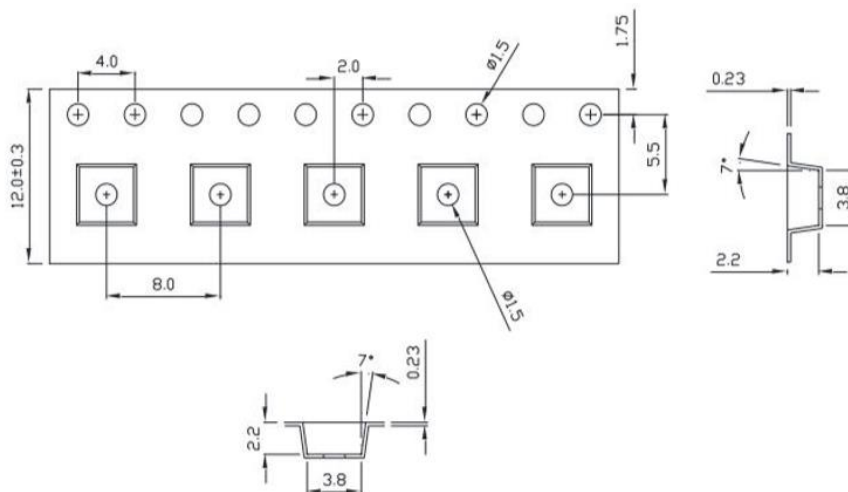

### Packaging

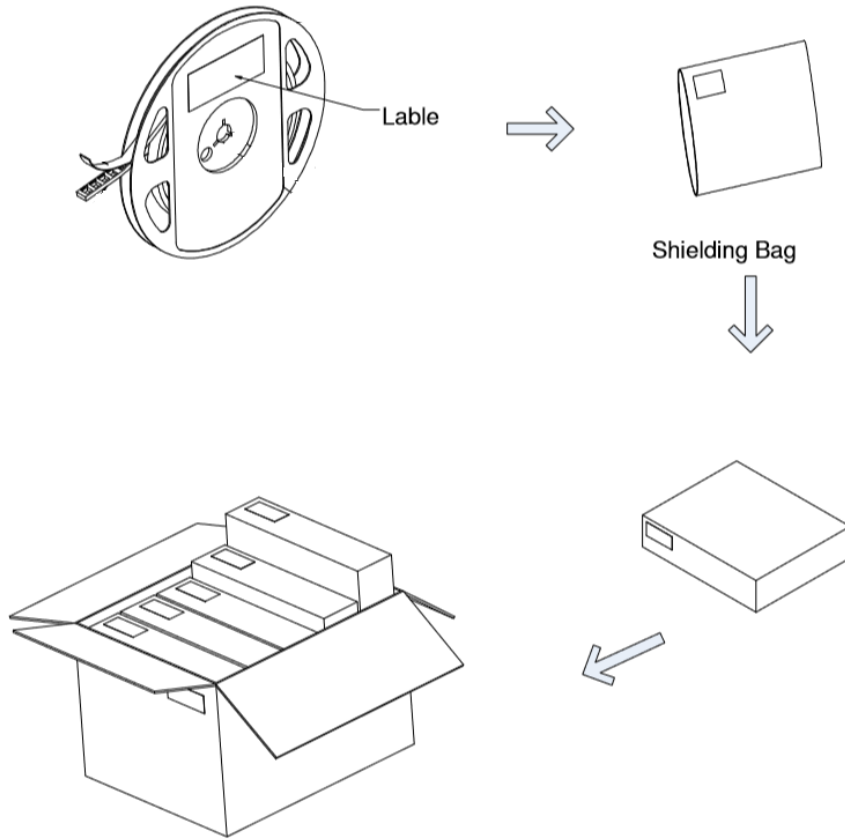

### LabelStyle

EKIINGLUX OPTOELECTRONICS(SHANGHAI) CO.,LTD  
 TEL:86 21 59909181      Sales@ekingluxs.com

  
 P/N:XXXXXXXXXXXXXXXXXX

Emitting Color: XXXX  
 HUE: XXX-XXX nm  
 IV : XXX-XXX mcd **example**  
 VF: XX-XX V  
 QTY: XX PCS



  
 BIN Code: XX  
 DATE: XXXX/XX/XX

  
 LOT NO.:XXXXXXX

**Table of Classification Reflow Profiles**

| Profile Feature  | Sn-Pb Eutectic Assembly | Pb-Free Assembly |
|--|-------------------------|------------------|
| Preheat & Soak   | 100 °C                  | 150 °C           |
| Temperature min (T <sub>smin</sub> )   | 150°C                   | 200 °C           |
| Temperature max (T <sub>smax</sub> )   | 60-120 seconds          | 60-120 seconds   |
| Time (T <sub>smin</sub> to T <sub>smax</sub> ) (t <sub>s</sub> )                                 |                         |                  |
| Average ramp-up rate (T <sub>smax</sub> to T <sub>p</sub> )                                      | 3 °C/second max         | 3 °C/second max  |
| Liquidous temperature (T <sub>L</sub> )  | 183 °C                  | 217 °C           |
| Time at liquidous (t <sub>L</sub> )  | 60-150 seconds          | 60-150 seconds   |
| Peak package body temperature (T <sub>p</sub> )*   | 230 °C ~235 °C          | 255 °C ~260 °C   |
| Classification temperature (T <sub>c</sub> )   | 235 °C                  | 260 °C           |
| Time (t <sub>p</sub> ) within 5 °C of the specified Classification temperature (T <sub>c</sub> ) | 20 seconds              | 30 seconds       |
| Average ramp-down rate (T <sub>p</sub> to T <sub>smax</sub> )                                    | 6 °C/second max         | 6 °C/second max  |
| Time 25 °C to peak temperature   | 6 minutes max           | 8 minutes max    |

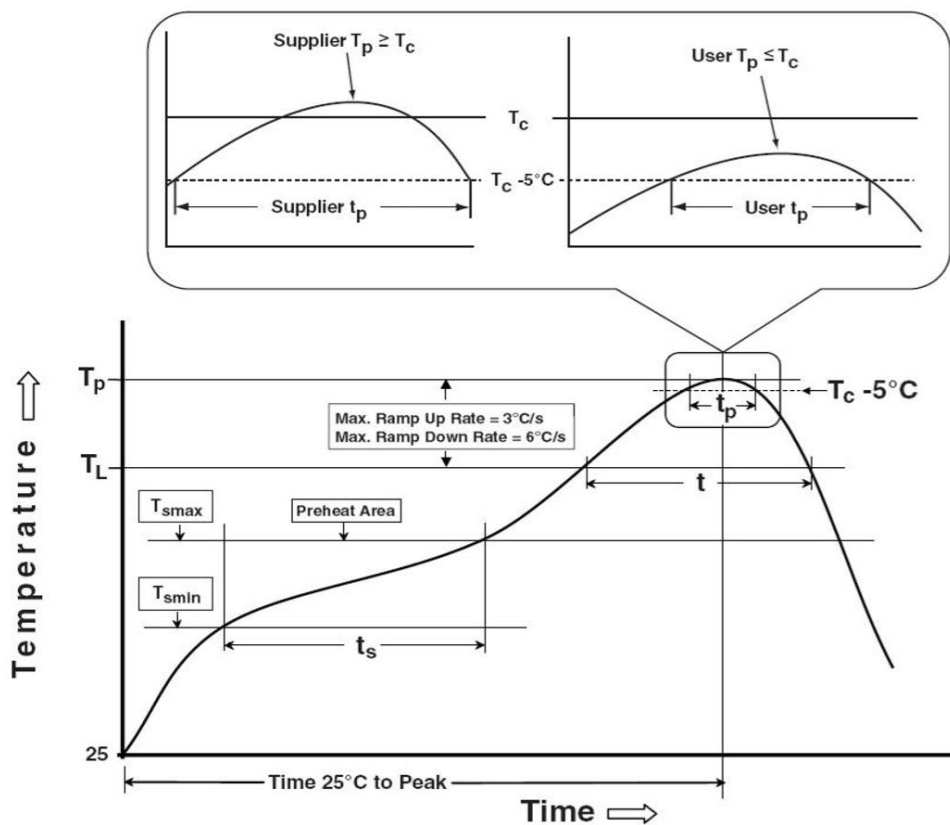
1. Tolerance for peak profile temperature (T<sub>p</sub>) is defined as a supplier minimum and a user maximum.
2. Tolerance for time at peak profile temperature (t<sub>p</sub>) is defined as a supplier minimum and a user maximum.



## Precautions

### 1. Storage:

- Moisture proof and anti-electrostatic package with moisture absorbent material is used, to keep moisture to a minimum.
- Before opening the package, the product should be kept at 30°C or less and humidity less than 60% RH, and be used within a year.
- After opening the package, the product should be stored at 30°C or less and humidity less than 10%RH. It is recommended that the product be operated at the workshop condition of 30°C or less and humidity less than 60%RH.
- If the moisture absorbent material has faded away or the LEDs have exceeded the storage time, baking treatment should be performed based on the following condition: (70±5)°C for 24 hours.

### 2. Static Electricity:

Static electricity or surge voltage damages the LEDs. Damaged LEDs will show some unusual characteristics such as the forward voltage becoming lower, or the LEDs do not light at the low current, even not light.

All devices, equipment and machinery must be properly grounded. At the same time, it is recommended that wrist bands or anti-electrostatic gloves, anti-electrostatic containers be used when dealing with the LEDs.

### 3. Vulcanization:

LED curing is due to sulfur being in brackets and the +1 price of silver in the chemical reaction generated Ag<sub>2</sub>S in the process. It will lead to the capacity of reflecting of silver layer reducing, light color temperature drift and serious decline, seriously affecting the performance of the product. So we should take corresponding measures to avoid vulcanization, such as to avoid using sulphur volatile substances and keeping away from high sulphur content of the material.