



# LIGHT EMITTING DIODE SPECIFICATION

DESCRIPTION: E6C1206RYKC2-A27AA-0.90T-RK01  
REVISION: V2.2  
ISSUE DATE: 2019-01-18

Contains trade secret information which is the property of Ekinglux and shall not be made available to, or copied or used by anyone outside Ekinglux without its written authorization. Copyright © 2017 Ekinglux Optoelectronics Technology Co., Ltd. All rights reserved

**Features:**

- Long operating life
- Low Power Consumption
- Wide Viewing Angle
- Low voltage DC operated
- RoHS Compliant

**Application:**

- Backlight
- Decoration lighting
- motormeter
- Indicator

| Part Number                   | Dice Material | Emitted Color    | Lens Color  |
|-------------------------------|---------------|------------------|-------------|
| E6C1206RYKC2-A27AA-0.90T-RK01 | AlGaInP-GaP   | Red-Yellow Green | Water Clear |

**Electro-Optical Characteristics** (Ta=25°C, @20mA)

| Parameter           | Color | Symbol | Min. | Typ. | Max. | Unit |
|---------------------|-------|--------|------|------|------|------|
| Luminous Intensity  | ■     | IV     | 70   | 100  | 150  | mcd  |
|                     | ■     |        | 30   | 40   | 70   |      |
| Radiation Bandwidth | ■     | Δλ     | -    | 15   | -    | nm   |
|                     | ■     |        | -    | 30   | -    |      |
| Forward Voltage     | ■     | VF     | 1.90 | 2.00 | 2.40 | v    |
|                     | ■     |        | 1.90 | 2.00 | 2.40 |      |
| Dominant Wavelength | ■     | λd     | 620  | 625  | 630  | nm   |
|                     | ■     |        | 570  | 572  | 575  |      |
| Viewing Angle       | -     | 2θ1/2  | -    | 120  | -    | deg  |
| Reverse Current     | -     | IR     | -    | -    | 10   | uA   |

**Absolute Maximum Ratings** (Ta=25°C)

| Parameter  | Symbol | Max.             | Unit |
|--|--------|------------------|------|
| Peak Forward Current(1/10 Duty Cycle, 0.1ms Pulse Width) | IFP    | 100              | mA   |
| Forward Current  | IF     | 20               | mA   |
| Reverse Voltage  | VR     | 5                | v    |
| Electrostatic Discharge                                  | ESD    | 2000             | v    |
| Operating Temperature Range                              | Topr   | -40to+90         | °C   |
| Storage Temperature Range                                | Tstg   | -40to+90         | °C   |
| Reflow Soldering   | Tsld   | 260°C for 10secs |      |



### Optical & Electrical Characteristics

Relative Intensity vs.Wavelength

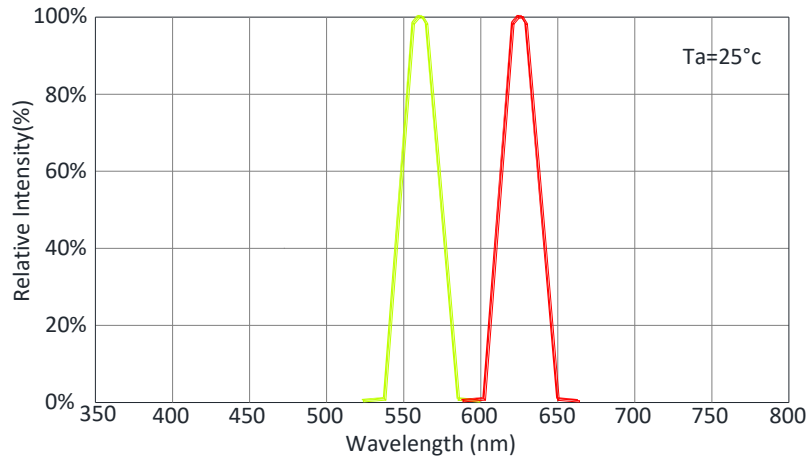

Forward Current vs.Forward Voltage

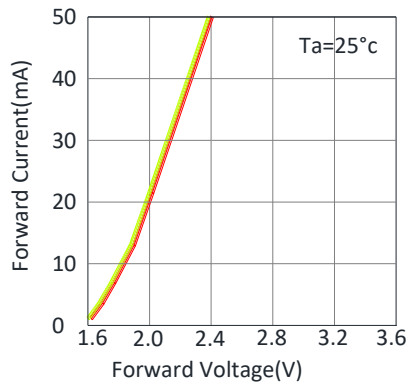

Forward Current vs.Ambient Temperature

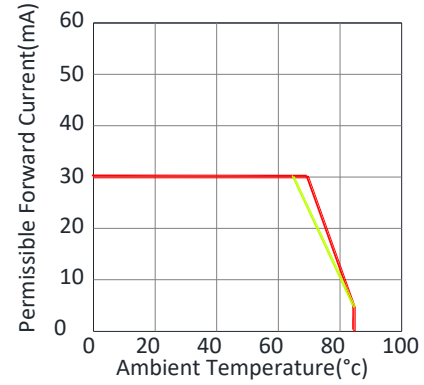

Relative Intensity vs.Forward Current

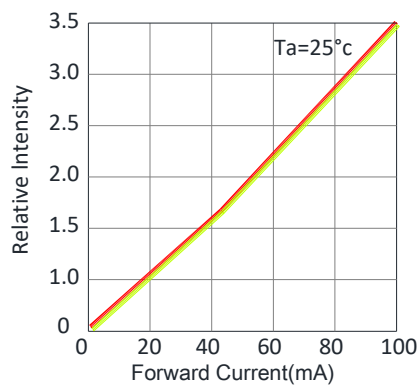

Relative Intensity vs.Ambient Temperature

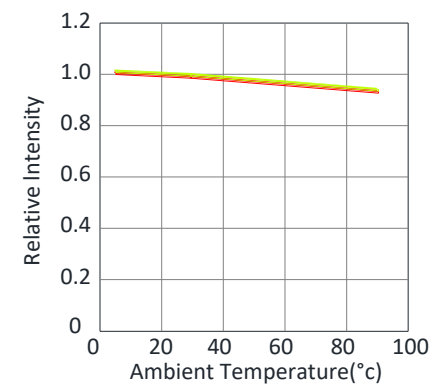

Radiation Pattern

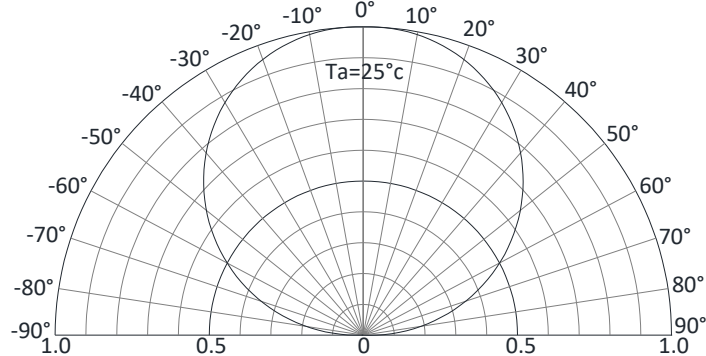

**Reliability Test Items And Conditions**

| Test Items                                | Reference                  | Test Conditions                 | Time          | Quantity | Criterion |
|---|----------------------------|---------------------------------|---------------|----------|-----------|
| Thermal Shock                             | MIL-STD-202G               | -40°C (30min)<br>-100°C (30min) | 100<br>Cycles | 22       | 0/22      |
| Temperature And Humidity<br>Cyclic        | JEITA ED-4701 200<br>203   | -10°C~65°C ;<br>0%~90%RH        | 10cycles      | 22       | 0/22      |
| High Temperature Storage                  | JEITA ED -4071 200<br>201  | Ta=100°C                        | 1000H         | 22       | 0/22      |
| Low Temperature Storage                   | JEITA ED -4071 200<br>202  | Ta=-40°C                        | 1000H         | 22       | 0/22      |
| High Temperature High<br>Humidity Storage | JEITA ED -4071 100<br>103  | Ta=60°C ;<br>RH=90%             | 1000H         | 22       | 0/22      |
| High Temperature Life Test                | JESD22-A108D               | Ta=80°C                         | 1000H         | 22       | 0/22      |
| Life Test                                 | JESD22-A108D               | Ta=25°C<br>IF=5mA               | 1000H         | 22       | 0/22      |
| Resistance to Sodering<br>Heat            | GB/T 4937, II ,<br>2.2&2.3 | Tsol*=(240±5)<br>°C 10secs      | 2 times       | 22       | 0/22      |

**Criteria For Judging Damage**

| Test Items                      | Symbol         | Test Conditions                 | Criteria For Judging Damage   |
|---------------------------------|----------------|---------------------------------|---|
| Forward Voltage                 | V <sub>F</sub> | I <sub>F</sub> =I <sub>FT</sub> | Initial Data±10%  |
| Recerse Current                 | I <sub>R</sub> | V <sub>R</sub> =5V              | I <sub>R</sub> ≤10uA  |
| Luminous Intensity              | I <sub>V</sub> | I <sub>F</sub> =I <sub>FT</sub> | Average I <sub>V</sub> degradation≤30% ; Single LED I <sub>V</sub><br>degradation≤50% |
| Resistance to<br>Soldering Heat | -              | -                               | Material without internal cracks,no material<br>between stripped,no deaded light      |

**Product size (Unit:mm)**

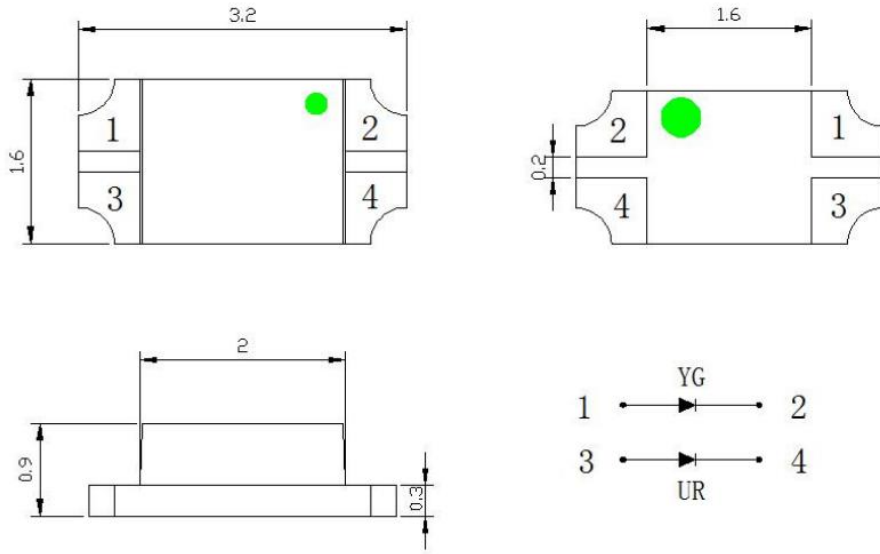

A27

**NOTES :**

1. All dimensions are in millimeters (inches)
2. Tolerances are  $\pm 0.2\text{mm}$  (0.008inch) unless otherwise noted

**Recommended Soldering Pad Design (Unit:mm)**

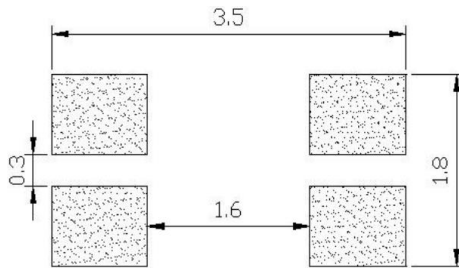

**Taping and package Spec**

- Tape Specification: 3,000pcs Per Reel

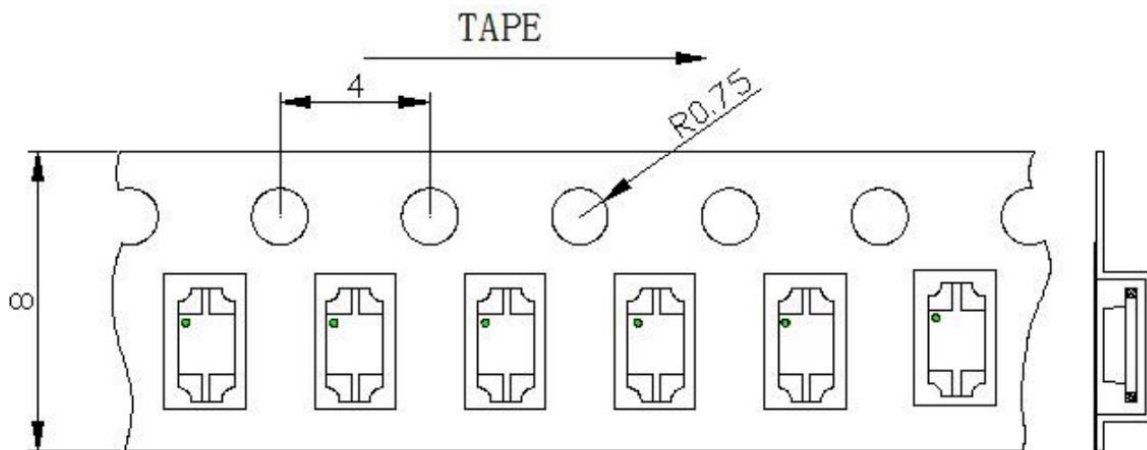

**Packaging**

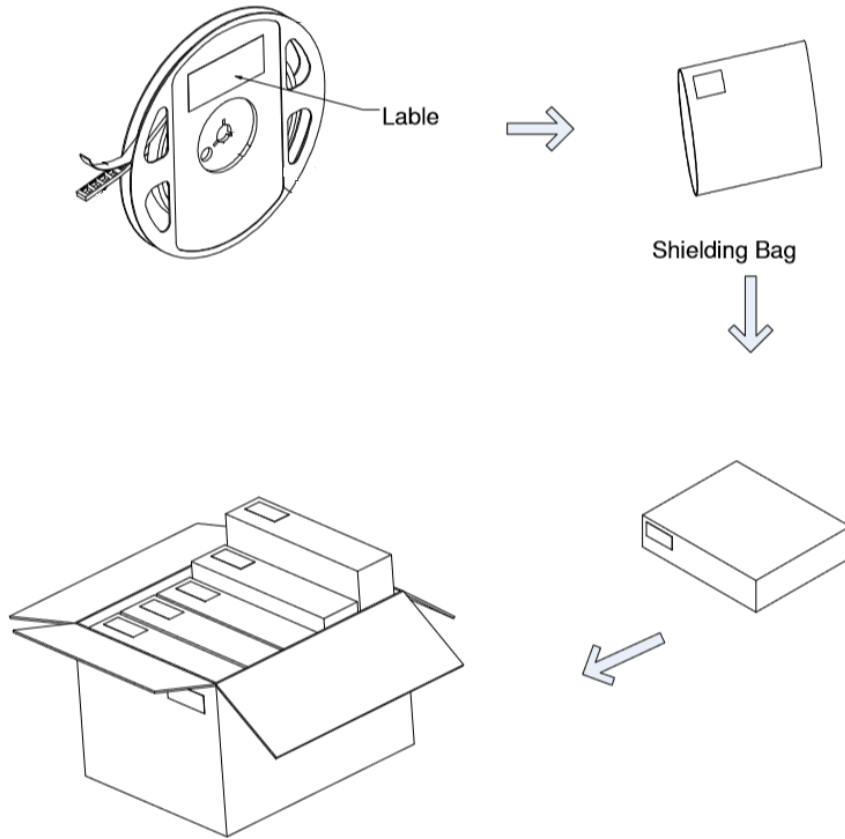

**LabelStyle**

EKINGLUX OPTOELECTRONICS(SHANGHAI) CO.,LTD  
 TEL:86 21 59909181      Sales@ekingluxs.com

  
 P/N:XXXXXXXXXXXXXXXXXX

Emitting Color: XXXX  
 HUE: XXX-XXX nm  
 IV : XXX-XXX mcd **example**  
 VF: XX-XX V  
 QTY: XX PCS

  
 BIN Code: XX  
 DATE: XXXX/XX/XX

  
 LOT NO.:XXXXXXX

**Table of Classification Reflow Profiles**

| Profile Feature  | Sn-Pb Eutectic Assembly | Pb-Free Assembly |
|--|-------------------------|------------------|
| Preheat & Soak   | 100 °C                  | 150 °C           |
| Temperature min (T <sub>sm</sub> )   | 150°C                   | 200 °C           |
| Temperature max (T <sub>sm</sub> )   | 60-120 seconds          | 60-120 seconds   |
| Time (T <sub>sm</sub> to T <sub>sm</sub> ) (ts)  |                         |                  |
| Average ramp-up rate (T <sub>sm</sub> to T <sub>p</sub> )  | 3 °C/second max         | 3 °C/second max  |
| Liquidous temperature (TL)   | 183 °C                  | 217 °C           |
| Time at liquidous (tL)   | 60-150 seconds          | 60-150 seconds   |
| Peak package body temperature (T <sub>p</sub> )*   | 230 °C ~235 °C          | 255 °C ~260 °C   |
| Classification temperature (T <sub>c</sub> )   | 235 °C                  | 260 °C           |
| Time (t <sub>p</sub> ) within 5 °C of the specified Classification temperature (T <sub>c</sub> ) | 20 seconds              | 30 seconds       |
| Average ramp-down rate (T <sub>p</sub> to T <sub>sm</sub> )                                      | 6 °C/second max         | 6 °C/second max  |
| Time 25 °C to peak temperature   | 6 minutes max           | 8 minutes max    |

1. Tolerance for peak profile temperature (T<sub>p</sub>) is defined as a supplier minimum and a user maximum.
2. Tolerance for time at peak profile temperature (t<sub>p</sub>) is defined as a supplier minimum and a user maximum.

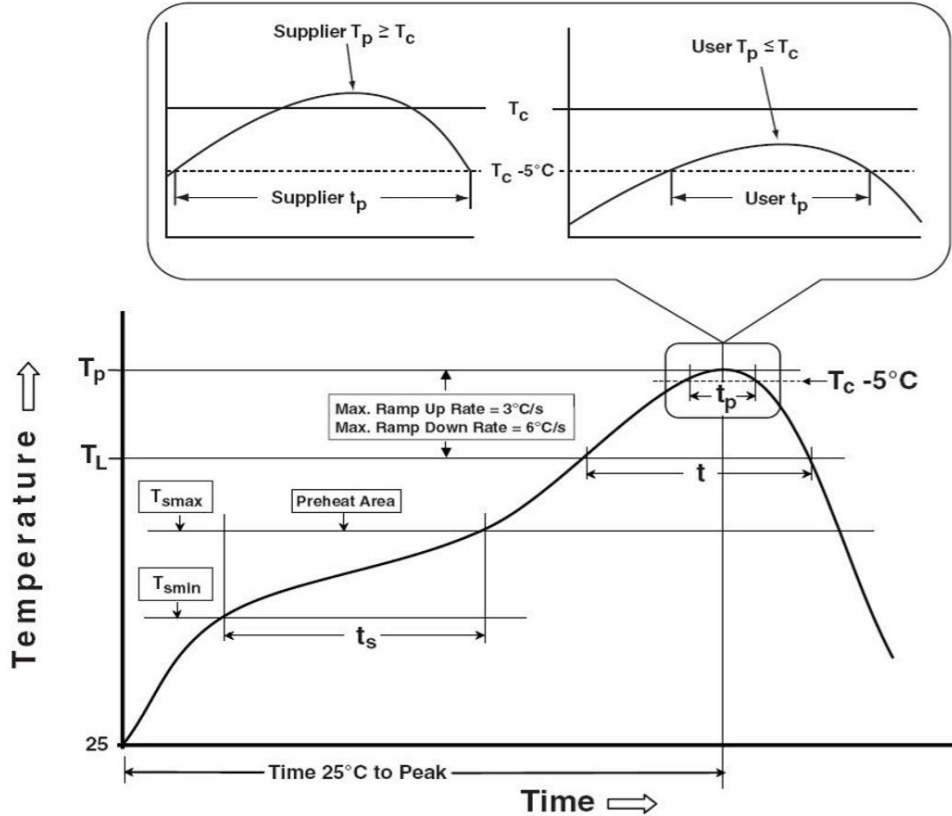



## Precautions

### 1. Storage:

- Moisture proof and anti-electrostatic package with moisture absorbent material is used, to keep moisture to a minimum.
- Before opening the package, the product should be kept at 30°C or less and humidity less than 60% RH, and be used within a year.
- After opening the package, the product should be stored at 30°C or less and humidity less than 10%RH, and be soldered within 24 hours (1day). It is recommended that the product be operated at the workshop condition of 30°C or less and humidity less than 60%RH.
- If the moisture absorbent material has faded away or the LEDs have exceeded the storage time, baking treatment should be performed based on the following condition: (70±5)°C for 24 hours.

### 2. Static Electricity:

Static electricity or surge voltage damages the LEDs. Damaged LEDs will show some unusual characteristics such as the forward voltage becoming lower, or the LEDs do not light at the low current, even not light.

All devices, equipment and machinery must be properly grounded. At the same time, it is recommended that wrist bands or anti-electrostatic gloves, anti-electrostatic containers be used when dealing with the LEDs.

### 3. Vulcanization:

LED curing is due to sulfur being in brackets and the +1 price of silver in the chemical reaction generated Ag<sub>2</sub>S in the process. It will lead to the capacity of reflecting of silver layer reducing, light color temperature drift and serious decline, seriously affecting the performance of the product. So we should take corresponding measures to avoid vulcanization, such as to avoid using sulphur volatile substances and keeping away from high sulphur content of the material.